

**BOYUTLAR / Dimensions**

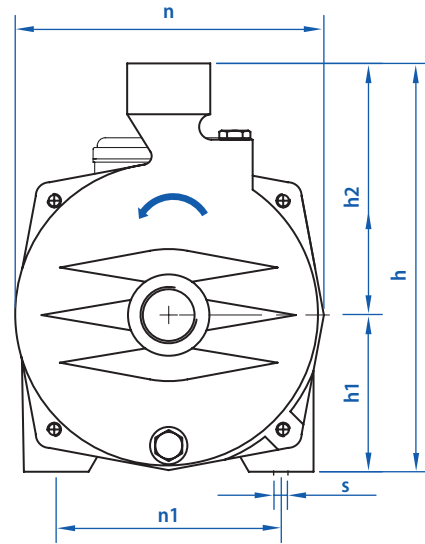
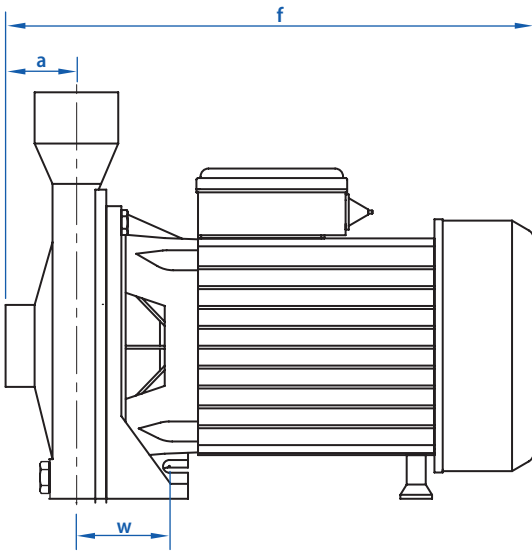

Pompa Tipi / Pump Type	Bağlantı Çapı / Connection		Boyutlar / Dimensions [mm]										Ağırlık / Weight [kg]
	Giriş / Suction	Çıkış / Discharge	a	f	h	h1	h2	h3	n	n1	w	s	
SPS 0,8 M	1"	1"	43	284	212	84	128	165	132	129	36	9	12
SPS 100 M-T	1"	1"	44	300	247	97	150	165	205	138	58	9	14.5
SPS 150 M-T	1 ½"	1 ½"	48	303	253	97	156	188	216	138	57	9	16
SPS 200 M-T	1 ½"	1 ½"	48	336	252	97	156	212	216	138	57	9	15